

# DISCOVERY DUO/K9-80

Dual-Technology Pet-Immune Intrusion Detector



Visonic

Installation Instructions

## 1. FEATURES

- Uses TSI™ - Target Specific Imaging technology for distinction between humans and pets (patent pending)
- Immune to pets weighing up to 36 kg (80 lb)
- **True Motion Recognition™ (TMR)** algorithm distinguishes between the true motion of a human body and other disturbances which invariably cause false alarms (patented)
- DRO-stabilized MW microstrip technology (patented)
- **MW Motion Simulator** simulates the effect created by a human body moving in the MW field (patent pending)
- Range control for adjusting the MW coverage
- Integral swivel bracket for wall or ceiling installation
- Sealed chamber protects the pyroelectric element from insects
- Programmable motion event counter (1 or 2 events)
- Simple-to-use three position vertical adjustment
- TEST input to remotely enable/disable the walk test LED (per new European standards)

- Open collector TROUBLE output
- White light protection

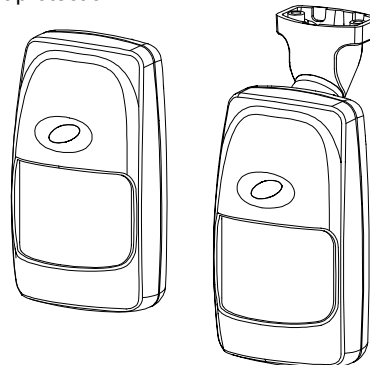

Figure 1. The DISCOVERY DUO/K9-80 Detector

## 2. SPECIFICATIONS

**Input Voltage:** 9 to 16 VDC

**Current Drain:** About 28 mA @ 12 VDC

### OPTICAL

**Max. Coverage:** Room of 12 m (40 ft) diagonal size / 90°

**Pet Immunity:** Immune to pets weighing up to 36 kg (80 lb)

**Vertical Adjustment:** 3-position adjustment scale: 1.8 m (6 ft), 2.1 m (7 ft) and 2.4 m (8 ft).

### PIR SECTION

**Detector:** Low noise dual-element pyroelectric sensor

**Tripping Indication:** LED flashes green for up to 5 seconds

**True Motion Event Verification Counter:** Selectable, 1 or 2 motion events

### MW SECTION

**Oscillator:** Microstrip DRO-stabilized Doppler module

**Frequency:** 10.525 GHz (U.S.A. only) or 2.45 GHz (Europe)

**Detection Range:** Adjustable from 25% to 100% (3 m to 12 m)

**Trip Indication:** LED glows green for up to 5 seconds

### ALARM, TAMPER & TROUBLE DATA

**Alarm Indication:** LED glows red for 1.3 to 5 seconds if both detectors trip

**Relay Contacts:** N.C., rated at 0.1 A resistive / 30 VDC; 18 Ω resistor in series with contacts

**Alarm Duration:** 1.3 to 5 seconds (LED glows red and output relay contacts open)

**Tamper Switch:** N.C., rated at 50 mA resistive / 30 VDC

**Trouble Output:** Open collector, 100 mA max., with 18Ω resistor in series and 47 kΩ pull-up (see Figure 11)

### MOUNTING

**Height:** Up to 2.4 m (8 ft)

**Installation Options:** Surface or corner (without bracket); surface or ceiling (with bracket).

**Bracket Adjustment:** 20° downward (only in non-pet immune applications), 20° left and right.

### ENVIRONMENTAL

**RFI Protection:** >30 V/m up to 1000 MHz.

**Operating Temperatures:** -10°C to 50°C (14°F to 122°F).

**Storage Temperatures:** -20°C to 60°C (-4°F to 140°F).

**Compliance with Standards:** Designed to meet FCC part 15;

This device complies with the essential requirements and provisions of Directive 1999/5/EC of the European Parliament and of the Council of 9 March 1999 on radio and telecommunications terminal equipment.

**2.45 GHz has no restriction in any EU member state.**

To comply with the Canadian standard RSS-210, this device must be operated **indoors only** to provide maximum shielding and to prevent interference to licensed services.

### PHYSICAL

**Dimensions (H x W x D):** 117 x 65 x 47 mm (4-5/8 x 2-9/16 x 1-7/8 in.).

**Weight:** 109 g (3.85 oz) w/o bracket, 124 g (4.4 oz) with bracket.

### PATENTS

**U.S. Patents:** 5,237,330 • 5,693,943 • 6,211,522

## 3. INSTALLATION

### 3.1 Installation Hints



**Important!** The detector is immune to 36 kg (80 lb) animals moving on the floor or climbing on furniture as long as the activity takes place below 1 m (3 ft). Above the 1 m (3 ft) height limit, the detector is immune to 18 kg (40 lb) pets, but the pet immunity will decrease as the pet gets closer to the detector. It is therefore recommended to select a mounting location that minimizes potential close proximity of animals.

### To minimize false alarms:

Do not aim at heat sources

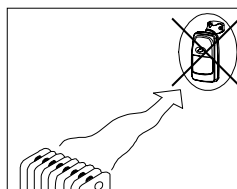

Mount on solid, stable surfaces

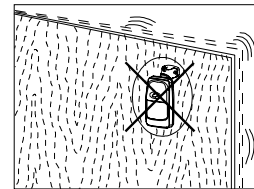

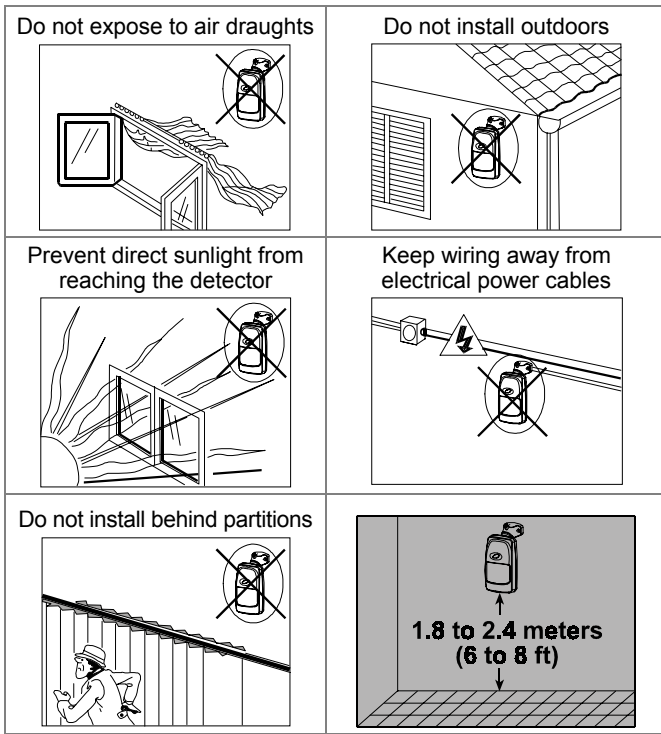

In addition, a few important rules must be observed while selecting a mounting location:

- A. Microwave radiation passes through glass and non-metallic walls. Be sure to adjust the MW range so that it does not exceed the room limits, or else motion in the next room or moving traffic along the outer side of the wall will cause the MW detector to trip.
- B. Large reflecting objects (especially metals) within the coverage area can distort the microwave detector's coverage pattern.
- C. If two DISCOVERY DUO/K9-80 units are installed in the same room or on opposite sides of a shared wall, they should not face each other and must be mounted at least 2 meters apart.
- D. Do not install the DISCOVERY DUO/K9-80 in places where one of the two detector circuits alarms constantly or intermittently, due to environmental interference.

### 3.2 Mounting without Swivel Bracket

A. Remove the front cover as shown in Figure 3.

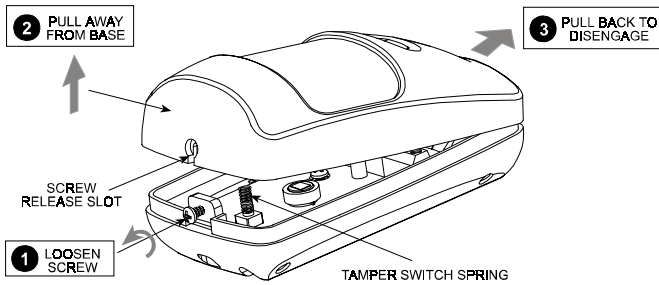

Figure 3. Cover Removal

- B. Loosen the vertical adjustment screw, slide the PCB down and remove it via the "keyhole" (see Figure 4).
- C. Pull the PCB straight out and put it aside until required again.

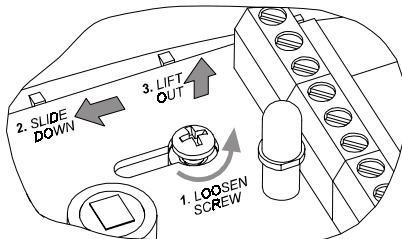

Figure 4. PCB Removal

D. Refer to Figure 5 and punch out the mounting knockouts at the rear wall of the base (for surface mounting) or at the angled sides of the base (for corner mounting).

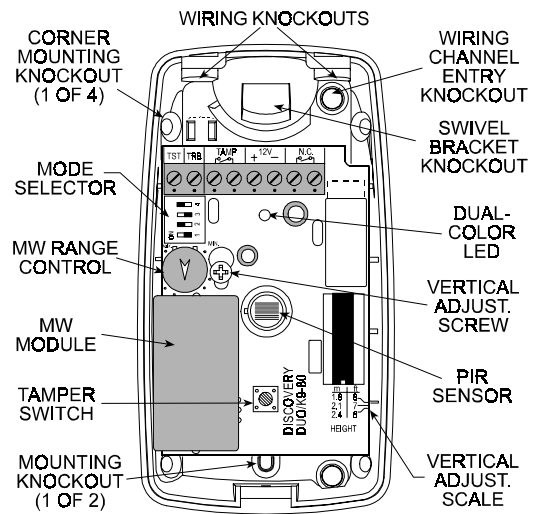

Figure 5. Inside View

- E. Punch out any one of the wiring knockouts shown in Figure 5.
- F. Hold the base against the wall at the selected installation location, mark the points for drilling and drill the holes (insert the plastic dowels supplied if necessary).
- G. Pass the wires through the wiring inlets into the base and attach the base to the wall using the screws supplied.
- H. Return the PCB to its place within the base.
- I. Proceed to wire the terminal block as instructed in Para. 3.4.

### 3.3 Mounting with Swivel Bracket

- A. Remove the front cover as shown in Figure 3.
- B. Remove the PCB (see Figure 4) and put it temporarily aside.
- C. Punch out the large knockout in the round bulge at the top part of the base (see Figure 6)

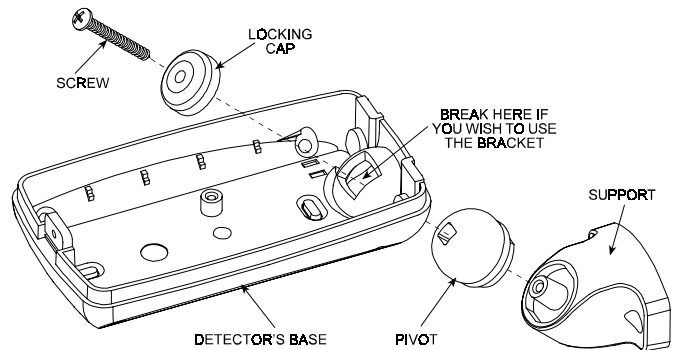

Figure 6. Attaching the Bracket

- D. Assemble the bracket as shown in Figure 6.
- E. Rotate the bracket to the desired position (see Figure 7) but do not yet tighten the screw fully.

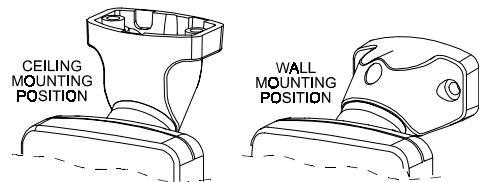

Figure 7. Wall and Ceiling Positions of Bracket

- F. Punch out the selected wiring knockouts in the bracket (see Figure 8).
- G. Press the bracket against the mounting surface and mark the points for drilling. Drill out the holes and insert plastic dowels.

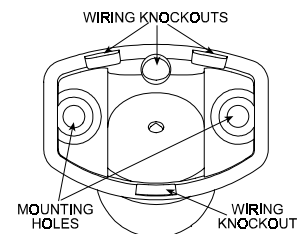

Figure 8. Bracket Base, Rear View

- H. Route the cable through the bracket and into the detector as shown in Figure 9.
- I. Attach the bracket to the mounting surface using the two screws supplied.
- J. Swivel the detector horizontally to face the desired direction, but do not tilt it if this is a pet immune application (see Figure 10). However, if pets are not present it is advisable to tilt the detector as much as 20° down.

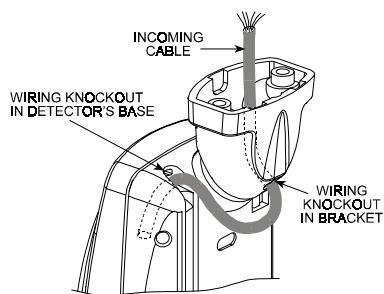

Figure 9. Routing the Cable

**IMPORTANT!** In pet-immune applications, the bracket should be used for horizontal alignment only. The detector should remain vertical (perpendicular to the floor).

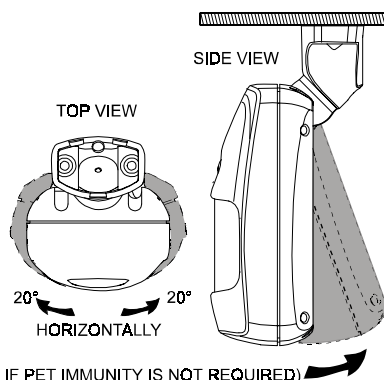

Figure 10. Tilt/Swivel Limits

- K. Having pointed the detector as desired, tighten the bracket screw strongly, to prevent any further change of position.

### 3.4 Wiring

Refer to Figure 11 and connect wires to the terminal block in the order given below:

**Terminal: TAMP**  
(tamper switch)

**Connect to:** A normally closed 24-hour tamper zone of the control panel.

**Details:** Upon removal of the cover, the tamper contacts open.

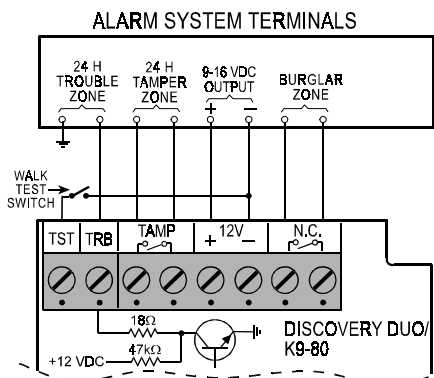

Figure 11. Terminal Block Wiring

**Terminal: NC** (alarm relay)

**Connect to:** Normally closed burglar protection zone.

**Details:** Upon alarm or power failure, the output relay's normally closed contacts open.

**Terminal: TRB** (trouble output)

**Connect to:** 24-hour trouble zone

**Details:** The TRB open collector output will be grounded upon detector malfunction, thus triggering the trouble zone.

**Alternative:** A buzzer or an interface relay may be connected across the TRB output and the 12 VDC (+) terminals.

**Terminal: TST** (TEST input)

**Connect to:** +12 VDC or ground potential (depending on the setting of DIP switch SW-3) via a test switch.

**Details:** Applying the trigger voltage to the TST input will enable the dual color LED for walk testing.

**Terminals: 12 V (+) and (-)**

**Connect to:** A power source within the range of 9 to 16 VDC.

**Details:** It is advisable to connect the power source only after all other connections have been completed and rechecked. Disconnect the AC mains from the alarm control panel and verify that

the voltage supplied to the detector is above 9 Volts with the backup battery as the only power source.

**IMPORTANT:** To comply with CE safety requirements, connect to CE-approved control panels with current-limited DC output.

**Note:** Use RTV to seal the base opening(s) to prevent insects from entering the detector.

### 3.5 The Power-up Process

After connecting the (+) and (-) terminals to the power source, the detector starts a 30-second warm-up period, indicated by alternate flashing of the green and red lights.

**Caution!** If the alternate flashing of the red and green lights does not stop within 30 seconds, a failure has been detected by the self-test circuitry.

### 3.6 Visual Indications

The dual color LED is used to signal various alarm and trouble messages as shown in Table 1 below:

Table 1. Interpreting the Visual Indications

Visual Indication	Significance
None	No detection
Steady green (5 s)	MW walk-test detection
Flashing green	PIR walk-test detection
Steady red (5 s)	Alarm: MW + PIR detection
Flashing red and green (alternately)	- Trouble is being detected by the self test circuitry, or - Initial warm-up routine (stops 30 seconds after power up).

**Notes:** 1. During walk testing, the green light lights steadily (MW detection) or flashes (PIR detection), depending on which one of the two detectors discovered the movement first. Upon subsequent discovery of the movement by the other detector, the green light goes off and the red light comes on (alarm).

2. If the LED maintains alternate red and green flashing beyond the warm-up period, a malfunction has been diagnosed. Replace the unit without delay.

### 3.7 Mode Selector

The DIP switch mode selector is mounted on the unit's PC board (see Figure 5). It controls four functions as demonstrated in Figure 12 and as detailed in Table 2.

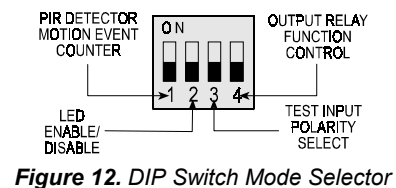

Figure 12. DIP Switch Mode Selector

Table 2. Mode Selector Switch functions

Switch	State	Function
SW-1	OFF	One motion event trips the PIR
	ON	Two motion events trip the PIR
SW-2	OFF	The walk-test LED is disabled*
	ON	The walk-test LED is enabled permanently
SW-3	OFF	LED enabled remotely by ground potential (-) applied to TST input; LED disabled by floating TST input (or by +12 VDC applied to the TST input).
	ON	LED enabled remotely by floating TST input (or by +12 VDC applied to the TST input); LED disabled by ground potential applied to the TST input.
SW-4	OFF	Output relay opens upon alarm
	ON	Output relay opens upon alarm and also when trouble is detected.

\* The LED may be enabled remotely with a test switch connected to the TST input as shown in Figure 11.

### 3.8 Vertical Adjustment

#### A. Pet-Immune Applications

To maintain maximum coverage range and pet immunity, the vertical adjustment scale must be adjusted in accordance with the actual mounting height (refer to Figure 13). Loosen the vertical adjustment screw and slide the printed circuit board up or down until the pointer shows the actual mounting height on the scale. When done, re-tighten the screw well.

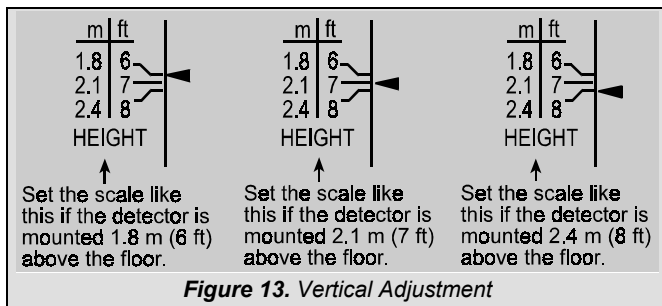

### B. Pet-Free Locations

To obtain the best coverage possible where no pets are present, mount the detector with the integral bracket at any desired height between 1.8 and 2.4 m (6 to 8 ft). Then set the vertical adjustment scale to the 2.4 m (8 ft) position and tilt the detector 20° down.

### 3.9 Setting the Motion Event Counter

If you wish to set the PIR detector for maximum false alarm immunity, shift DIP switch No. 1 (SW-1) to ON. In this position, two consecutive motion events are required to trip the PIR detector. For faster catch performance, shift SW-1 to OFF. In this position, only one motion event is required to trip the PIR detector.

### 3.10 PIR Walk Test

- Rotate the MW RANGE control fully counterclockwise to MIN.
- Verify that DIP switch SW-2 is set to ON (the LED is enabled).
- Mount the front cover in place.
- Walk into the detector's field of view at the expected far edge of the coverage area. The green light should flash for up to 5 seconds each time your motion is detected.

**Note:** If the green light glows steadily for up to 5 seconds, your motion has been detected by the MW detector.

- If PIR detection is not obtained at the far end of the coverage area, remove the front cover and re-adjust the vertical position. Replace the cover and retest.

### 3.11 MW Walk Test

- Remove the front cover.
- Verify that the MW RANGE control is set fully counterclockwise to MIN and that DIP switch SW-2 is set to ON (LED is enabled).
- Start by moving into the coverage area at the far edge. The LED should light green for up to 5 seconds each time your motion is detected.
- If your motion was not detected at the far edge, advance the MW RANGE control slightly clockwise toward MAX and try again until your motion is detected reliably at the far edge.

**Caution!** The MW detection range must not exceed the far edge of the desired coverage area.

- Walk across the coverage area at various ranges and verify that your motion is consistently detected.

**Note:** If PIR trips interfere with your test, disable the PIR by inserting a small piece of cardboard in front of the sensor.

### 3.12 Alarm Walk Test

- Set DIP switch SW-2 to ON (the LED is enabled).
- Install the front cover in place.
- Walk across the detector's field of view in different directions, at various distances from the detector, and verify proper alarming throughout the detector's coverage area (the red light glows for 1.3 to 5 seconds).
- When done, remove the cover and set DIP switch SW-2 to OFF to prevent unauthorized tracing of the coverage pattern.
- Remount the cover and fasten it to the base using the small screw at the bottom.

**Attention!** To assure proper function of the detector, the range and coverage area should be checked at least twice a year. Furthermore, it is recommended that users perform a walk test at the far end of the coverage pattern to assure an alarm signal prior to each time the alarm system is armed.

## 4. MISCELLANEOUS COMMENTS

This device has been tested and found to comply with the limits for a Class B digital device, pursuant to Part 15 of the FCC Rules. These limits are designed to provide reasonable protection against harmful interference in residential installations. This equipment generates, uses and can radiate radio frequency energy and, if not installed and used in accordance with the instructions, may cause harmful interference to radio and television reception. However, there is no guarantee that interference will not occur in a particular installation. If

this device does cause such interference, which can be verified by turning the device off and on, the user is encouraged to eliminate the interference by one or more of the following measures:

- Re-orient or re-locate the receiving antenna.
- Increase the distance between the device and the receiver.
- Connect the device to an outlet on a circuit different from the one which supplies power to the receiver.
- Consult the dealer or an experienced radio/TV technician.

### WARRANTY

Visonic Ltd. and/or its subsidiaries and its affiliates ("the Manufacturer") warrants its products hereinafter referred to as "the Product" or "Products" to be in conformance with its own plans and specifications and to be free of defects in materials and workmanship under normal use and service for a period of twelve months from the date of shipment by the Manufacturer. The Manufacturer's obligations shall be limited within the warranty period, at its option, to repair or replace the product or any part thereof. The Manufacturer shall not be responsible for dismantling and/or reinstallation charges. To exercise the warranty the product must be returned to the Manufacturer freight prepaid and insured.

**This warranty does not apply in the following cases:** improper installation, misuse, failure to follow installation and operating instructions, alteration, abuse, accident or tampering, and repair by anyone other than the Manufacturer.

This warranty is exclusive and expressly in lieu of all other warranties, obligations or liabilities, whether written, oral, express or implied, including any warranty of merchantability or fitness for a particular purpose, or otherwise. In no case shall the Manufacturer be liable to anyone for any consequential or incidental damages for breach of this warranty or any other warranties whatsoever, as aforesaid.

This warranty shall not be modified, varied or extended, and the Manufacturer does not authorize any person to act on its behalf in the modification, variation or extension of this warranty. This warranty shall apply to the Product only. All products, accessories or attachments of others used in conjunction with the Product, including batteries, shall be covered solely by their own warranty, if any. The Manufacturer shall not be liable for any damage or loss whatsoever, whether directly, indirectly, incidentally, consequentially or otherwise, caused by the malfunction of the Product due to products, accessories, or attachments of others, including batteries, used in conjunction with the Products.

The Manufacturer does not represent that its Product may not be compromised and/or circumvented, or that the Product will prevent any death, personal and/or bodily injury and/or damage to property resulting from burglary, robbery, fire or otherwise, or that the Product will in all cases provide adequate warning or protection. User understands that a properly installed and maintained alarm may only reduce the risk of events such as burglary, robbery, and fire without warning, but it is not insurance or a guarantee that such will not occur or that there will be no death, personal damage and/or damage to property as a result.

**The Manufacturer shall have no liability for any death, personal and/or bodily injury and/or damage to property or other loss whether direct, indirect, incidental, consequential or otherwise, based on a claim that the Product failed to function.** However, if the Manufacturer is held liable, whether directly or indirectly, for any loss or damage arising under this limited warranty or otherwise, regardless of cause or origin, the Manufacturer's maximum liability shall not in any case exceed the purchase price of the Product, which shall be fixed as liquidated damages and not as a penalty, and shall be the complete and exclusive remedy against the Manufacturer.

**Warning:** The user should follow the installation and operation instructions and among other things test the Product and the whole system at least once a week. For various reasons, including, but not limited to, changes in environmental conditions, electric or electronic disruptions and tampering, the Product may not perform as expected. The user is advised to take all necessary precautions for his/her safety and the protection of his/her property.

6/91



VISONIC LTD. (ISRAEL): P.O.B 22020 TEL-AVIV 61220 ISRAEL. PHONE: (972-3) 645-6789, FAX: (972-3) 645-6788  
 VISONIC INC. (U.S.A.): 10 NORTHWOOD DRIVE, BLOOMFIELD CT. 06002-1911. PHONE: (860) 243-0833, (800) 223-0020 FAX: (860) 242-8094  
 VISONIC LTD. (UK): FRASER ROAD, PRIORY BUSINESS PARK, BEDFORD MK44 3WH. PHONE: (0870) 730-0800 FAX: (0870) 730-0801  
 INTERNET: www.visonic.com

©VISONIC LTD. 2003 DISCOVERY DUO/K9-80 DE1842- (REV. 5, 1/03)

